

LX Signature Fold

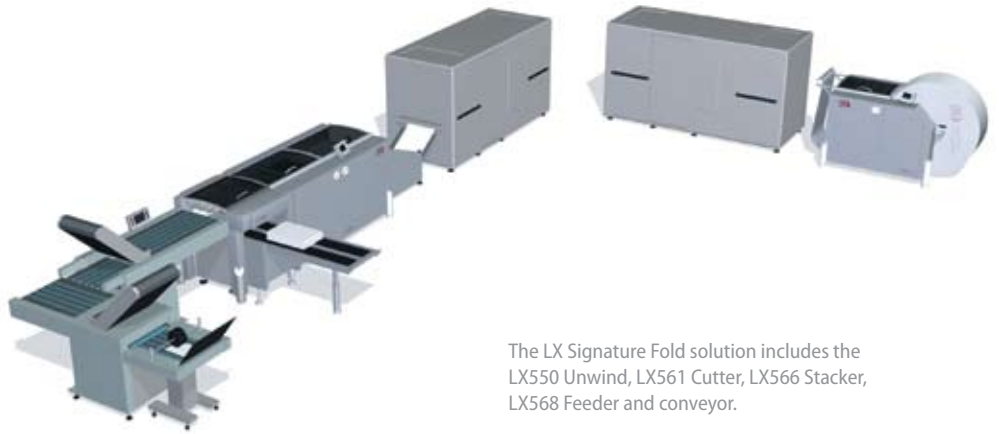

The LX Signature Fold solution includes the LX550 Unwind, LX561 Cutter, LX566 Stacker, LX568 Feeder and conveyor.

- Signatures created in-line
- Lightweight compatible
- Flexible operation
- Easy application changes

In-line signature folds, and more

Prepare book signatures quickly and easily in-line with your digital web printer. The LX Signature Fold solution effortlessly produces folded forms or signatures for print on demand applications including short-run books and stitched booklets, as well as for direct mail.

The LX Signature Fold precisely cuts and delivers sheets as light as 11# bond or 40 gsm to an in-line folder, for signatures of up to 32 pages. Off-line labor is reduced, and jobs are completed sooner. Not only does this system create superior folded signatures, the bypass function makes it easy to alternate from cut and stacked to folded applications, providing the flexibility critical to your operation.

As with all of our products, the LX Signature Fold is compatible with today's most advanced digital printers and can be adapted to meet your printing needs. Global service and around-the-clock support help ensure our reputation as the industry's reliability leader. Count on Lasertec Roll Systems to help you do more with digital print.

LX Signature Fold

The LX Signature Fold solution features the LX550 Unwind, LX561 Cutter and LX566 Stacker, LX568 Feeder and conveyor operating with a third-party folder to produce multi-folded signatures in-line.

The center-shaft driven LX550 Unwind feeds a roll of paper up to 20.5" wide and 52" in diameter into the printer for continuous printing. Once the paper is printed, the LX561 uses a rotary knife to cut printed output to the desired length.

Individual sheets are then bypassed through the LX 566 Stacker and the LX568 Feeder squares the sheets and delivers them to the folder. The sheets are multi-folded to create signatures with up to 32 pages, depending on the folder configuration. Signatures can then be gathered into sets for near-line binding. The LX Signature Fold solution is an ideal method for perfect-bound books requiring lightweight paper.

For stacked cut sheet book blocks, the LX566 Stacker builds 8.5" stacks of sheets. Using the most advanced technology available, stacks



Offset stacks.

created with the LX Signature Fold solution are clean and tightly trimmed. Once paper is accurately cut and stacked, each set can be delivered to the conveyor one at a time, individually offset within the stack or when the operator-programmed stack height is reached. Book blocks can then be easily transported to near-line finishing units, such as Binders or Stitchers.

Output delivery options are easily switched with no movement of modules, to offer the flexibility you need for your print on demand applications. All components are modular, compact, and are designed to dramatically improve workflow.

Optional Capabilities

Lightweight Paper

For lightweight paper applications, add the optional LX530 Buffer to the LX Signature Fold

system. Positioned between the printer and the LX561 Cutter, the LX530 Buffer accumulates the lightweight paper web and weaves it through rollers that rise and fall, filling the buffer and allowing job delivery without stopping the printer.



LX535 Merger

between the printer and the LX561 Cutter*, the web enters the LX535 Merger and is slit in the center. A sensor continuously monitors the web for side-to-side variations or movement and the slitter automatically adjusts to cut precisely at the center of the web. The resulting two webs are then merged right-over-left or left-over-right, depending on the requirements of the application.

*Pinless slit merge applications require the LX562 Cutter.

LX562 Cutter

Same features as the LX561, plus the ability to process pinless slit merge applications.

Web Vision™

Monitor print, data and workflow quality.

Specifications

Performance / Media-Stacking

Speed Max.	450 ft/min	2.25 m/sec
Print	Simplex, Duplex	
Feeding	Pinfed or pinless	
Paper weight	11# bond-110# index	40-200 gsm <small>(Testing mandatory for paper less than 55 gsm)</small>
Roll diameter	4"-52"	100 mm-1320 mm
Web width	5.5"-20.5"	140 mm-520 mm
Form length		
Stacks	3.5"-19.5"	90 mm-495 mm
Signatures	48"	1220 mm
Stack Height	Max. 8.5"	216 mm
Offset	0.6"	15 mm
Output options	1-, 2-, 3-up with offset	

Electrical

Power	208 VAC, 1 Phase, 15A, or 200-240 VAC 50/60 Hz, 10A
--------------	--

Configuration Example

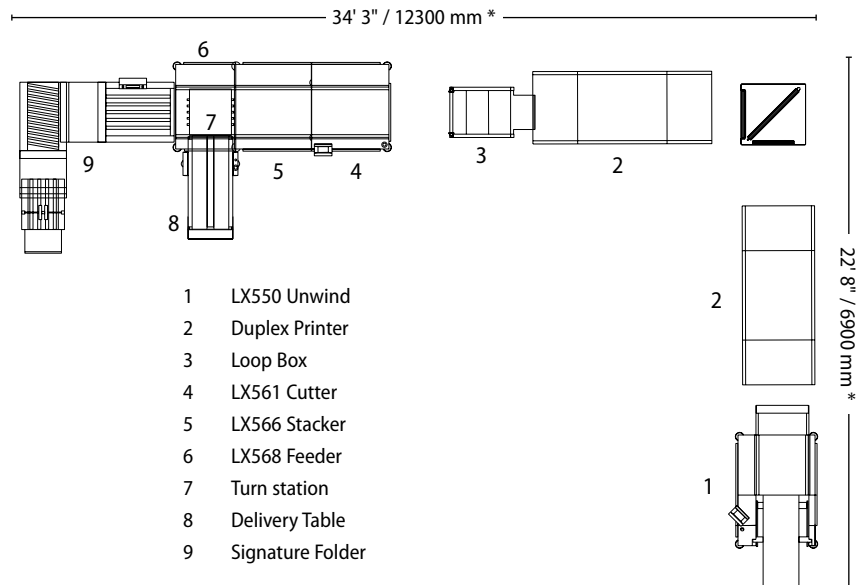

*Length will vary by printer model.