

LX Saddle Stitch

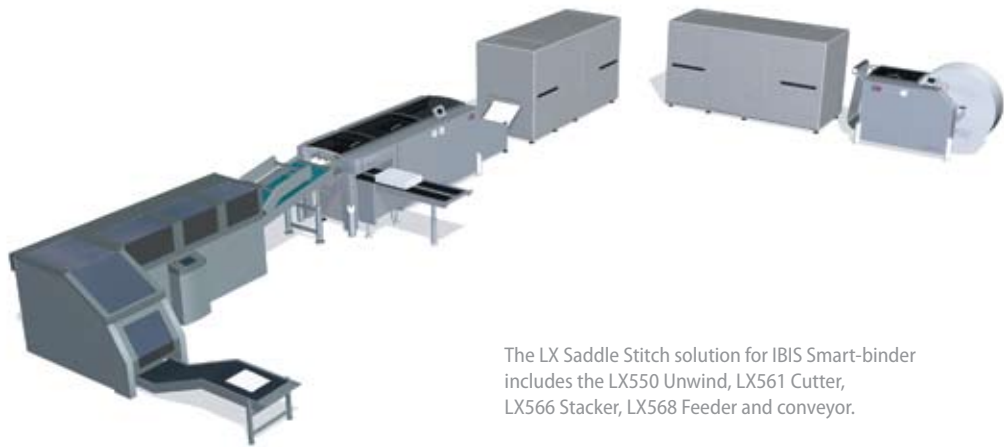

The LX Saddle Stitch solution for IBIS Smart-binder includes the LX550 Unwind, LX561 Cutter, LX566 Stacker, LX568 Feeder and conveyor.

- **In-line saddle stitching**
- **Stacking for near-line finishing**
- **Lightweight compatible**
- **Easy application changes**

A stitch in time

Saddle stitch in-line with your digital web printer for quick and effortless production of manuals and booklets. The LX Saddle Stitch works with the IBIS Smart-binder to provide unprecedented stitching capability and maximum flexibility for print on demand applications.

The LX Saddle Stitch solution delivers sheets in-line to the IBIS to be stitched and trimmed in-line, in paper weights as light as 14 pound bond or 50 gsm. Off-line labor is eliminated, and jobs are completed sooner. The bypass function allows quick and easy changing between stitched booklets and cut sheet, stacked output.

As with all of our products, the LX Saddle Stitch is compatible with today's most advanced digital printers and can be adapted to meet your printing needs. Global service and around-the-clock support help ensure our reputation as the industry's reliability leader. Count on Lasertech Roll Systems to help you do more with digital print.

LX Saddle Stitch

The LX Saddle Stitch solution for IBIS Smart-binder features the LX550 Unwind, LX561 Cutter, LX566 Stacker, LX568 Feeder and conveyor, and generates individual sheets for in-line stitching or neat paper stacks for book blocks.

The center-shaft driven LX550 Unwind feeds a roll of paper up to 20.5" wide and 52" in diameter into the printer for continuous printing. Once the paper is printed, the LX561 Cutter uses a rotary knife to cut printed output to the desired length.

For stitched booklets, individual sheets are then bypassed through the LX566 Stacker and the LX568 Feeder delivers them in sequence to the Smart-binder. There, each sheet is individually scored, folded and collated into a set, then stitched and trimmed to create a finished booklet, with or without a printed cover.

For near-line or off-line finishing, the LX566 Stacker builds 8.5" stacks. Using the most advanced technology available, stacks created with the LX Saddle Stitch solution are clean and tightly trimmed. Once paper is accurately cut

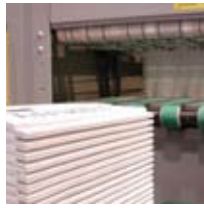

Offset stacks.

1-up, 2-up or 3-up, and can then be easily transported to near-line finishing units, such as Binders or Stitchers.

Output delivery options are easily switched with no movement of modules, to offer the flexibility you need for your print on demand applications. All components are modular, compact, and are designed to dramatically improve workflow.

Optional Capabilities

Lightweight Paper

For lightweight paper applications, add the optional LX530 Buffer to the LX Saddle Stitch system. Positioned between the printer and the LX561 Cutter, the LX530 Buffer accumulates the

lightweight paper web and weaves it through rollers that rise and fall, filling the buffer and allowing job delivery without stopping the printer.



LX535 Merger

the web enters the LX535 Merger and is slit in the center. A sensor continuously monitors the web for side-to-side variations or movement and the slitter automatically adjusts to cut precisely at the center of the web. The resulting two webs are then merged right-over-left or left-over-right, depending on the requirements of the application.

*Pinless slit merge applications require the LX562 Cutter.

LX562 Cutter

Same features as the LX561, plus the ability to process pinless slit merge applications.

Web Vision™

Monitor print, data and workflow quality.

Specifications

Performance / Media-Stacking

Speed Max.	450 ft/min	2.25 m/sec
Print	Simplex, Duplex	
Feeding	Pinfed or pinless	
Paper weight	11# bond-110# index	40-200 gsm (Testing mandatory for paper less than 55 gsm)
Web width	5.5"-20.5"	140 mm-520 mm
Form length	3.5"-19.5"	90 mm-495 mm
Stack Height	Max. 8.5"	216 mm
Output options	1-, 2-, 3-up with offset	

Stitching

Speed	6000 books per hour	
Sheet width	9.4"-17.5"	238 mm-450 mm
Book width	4.7"-8.75"	119 mm-225 mm
Spine length	4"-12.5"	97 mm-320 mm
Paper weight	14-35# bond	50-130 gsm
Book thickness	2-50 sheets	Max. 10 mm

Configuration Example

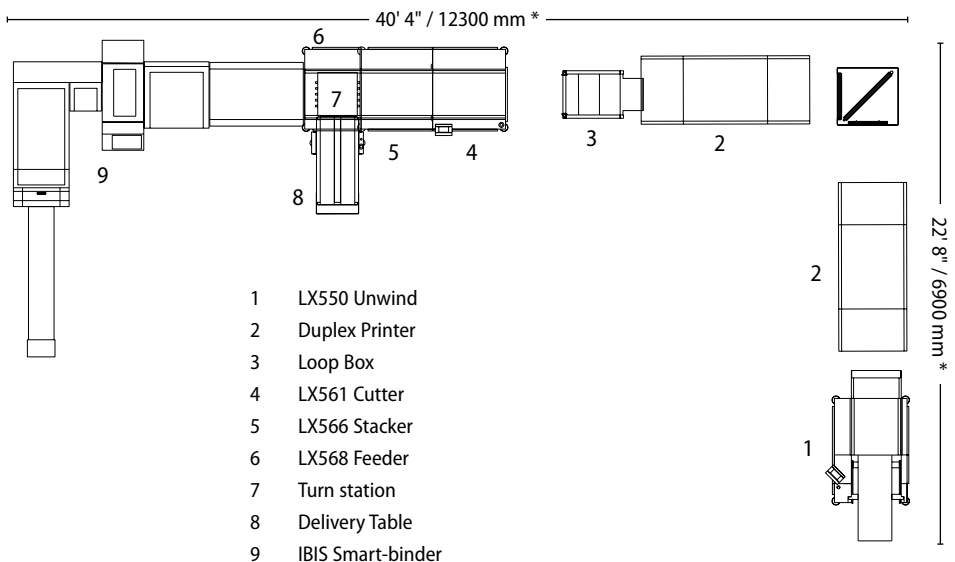

*Length will vary by printer model.